

APR™ 1000-2S

Dear customer,

Congratulations, you have purchased an **Cams shredder**.

The **APR 1000-2s** model is a unique machine.

It offers the perfect match between simple and efficient design and a state-of-the-art technology.

Please carefully read this **User manual** before starting the shredder, using it or executing maintenance interventions. Knowing and respecting the dispositions contained therein, you will be able to correctly and safely use and preserve our paver finisher. In this regard, you undertake part of the responsibility regarding the safe use of the machine, committing to avoid faults and accidents.

Also included in this User manual are the **warnings and use indications** to sensitise you on the significant dangers and technical aspects.

- The Warnings describe the various dangers and indicate the preventive measures to undertake.
- The Use indications give additional information that facilitate and promote the understanding of the use methods of the paver finisher.

This User manual is **integrating part of the shredder**. Please always keep it at hand on the shredder. Should the User manual be lost, damaged or become illegible, please replace it. In case of selling the shredder, please deliver the User manual to the new owner.

Kind regards,

Plant address:

Via Giulio Golini, 301
40024 Castel San Pietro Terme (BO)
Tel. +39 (0)51 6946611 – Fax +39 (0)51 6946650
www.camssrl.it

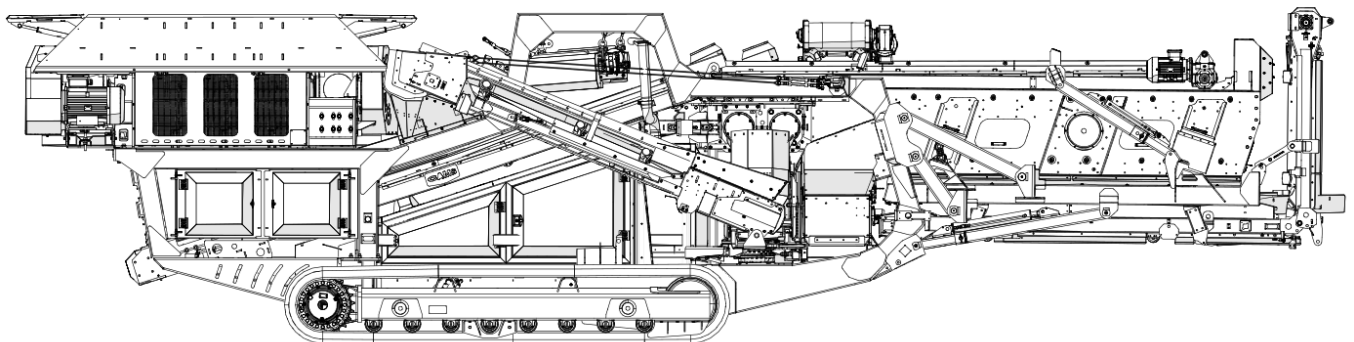

**C
H
A
P
T
E
R**

1

GENERAL INFORMATION

INDEX





1. GENERAL INFORMATION.....	5
1.1 SYMBOLS USED IN THE MANUAL.....	5
1.2 DESCRIPTION OF DANGER, PROHIBITION AND OBLIGATION SIGNS.....	6
1.3 WARNINGS FOR THE PURCHASER	10
1.4 INTRODUCTION.....	13
1.5 MANUFACTURER'S DETAILS	13
1.6 SAFETY REGULATIONS IN THE MANUAL	14
1.7 COMMISSIONING PROTOCOL	16
1.8 GLOSSARY OF THE TERMS USED.....	16
1.9 PERSONNEL QUALIFICATION	21
1.10 DESCRIPTION OF THE PERSONAL PROTECTIVE EQUIPMENT (PPE)	21
1.11 MANUAL LANGUAGE	24
1.12 WARRANTY	24
1.13 MACHINE/PLANT MANAGEMENT.....	25

1. GENERAL INFORMATION



1.1 SYMBOLS USED IN THE MANUAL











Some symbols are used in the manual to draw the reader's attention and highlight some particularly important aspects of the discussion.

The safety signs assume different meaning in relation to the colour and geometric shape, in particular please note the following:

<i>MEANING</i>	<i>SHAPE</i>	<i>COLOUR</i>
Danger		Yellow
Prohibition		Red
Obligation		Blue
Information		Blue



The following table describes the meaning of the different symbols used in this manual.











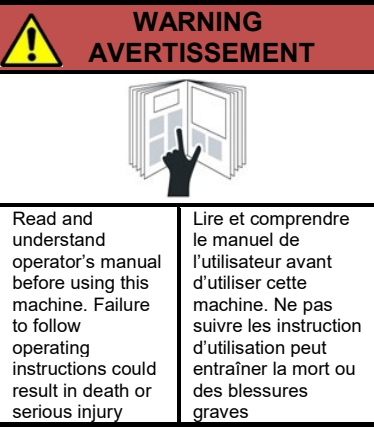

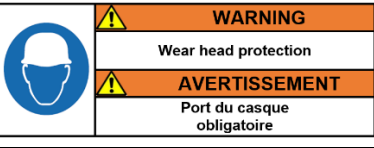

SYMBOL		MEANING	NOTES
		Danger	

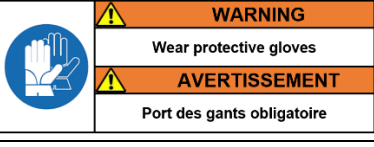



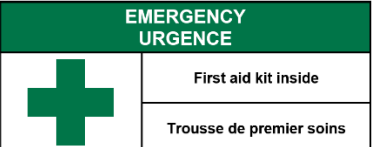

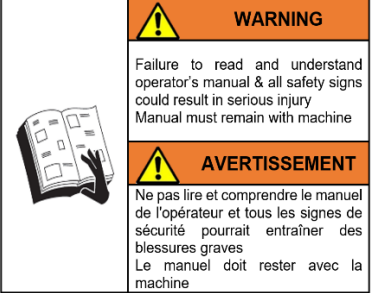

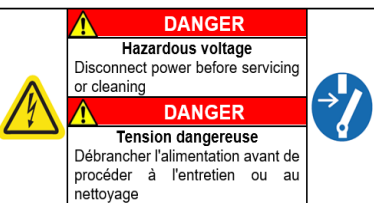









			Indicates a situation of imminent risk, high risk, which, if not avoided, can cause death or serious injuries
		Warning	Indicates a potentially dangerous situation, average risk, which, if not avoided, can cause death or serious injuries
		Caution	Indicates a potentially dangerous situation, low risk, which, if not avoided, can cause minor or moderate injuries and/or property damage.
		Important	Obligation for a behaviour and special activities to safely manage the machine. Represents a warning of possible deterioration or damage to the machine, equipment or other personal object of the purchaser/user.
		Information	The blocks of text containing complementary information are introduced by this symbol. This information has no direct relationship with the description of a function or development of a procedure. It can refer to other complementary documentation such as, for example, instruction manuals for use, annexes, technical documents or other sections of this manual.
		Special tool	Indicates that it is operationally necessary to use a special tool or equipment.
		Visual inspection	Indicates that the reader must proceed with a visual inspection. This symbol can also be found in the operating instructions. The user is required to read a measurement value, check a signal, etc.
			At the end of its useful life, the product must be collected separately from other waste.













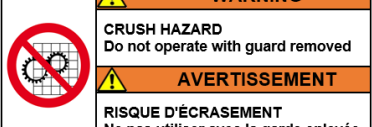

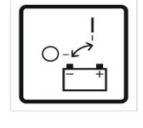
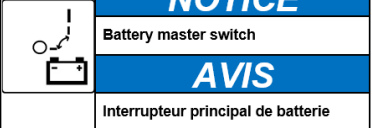

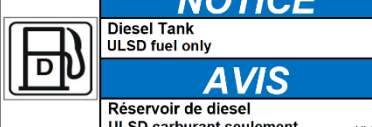
1.2 DESCRIPTION OF DANGER, PROHIBITION AND OBLIGATION SIGNS



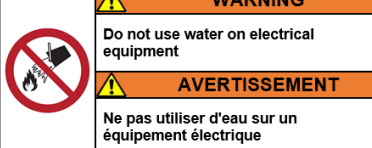



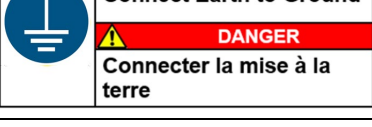

This paragraph gives an explanation of the warning plates that can be potentially present on the machine. The details of the warning plates actually applied on the machine can be found on chap.4 paragraph "Warning plates on the machine".

	<p>FOR MACHINES SOLD ON THE EUROPEAN MARKET AND CE MARKED, THE MANUFACTURER PROVIDES WARNING PLATES ACCORDING TO THE ISO STANDARD, WHILE FOR MACHINES SOLD ON THE AMERICAN MARKET THE MANUFACTURER PROVIDED PLATES ACCORDING TO THE ANSI 535 STANDARD. THIS SECTION SHOWS BOTH STANDARDS WITH THE RELEVANT EXPLANATORY NOTES.</p>	
---	--	---

Ref.	PLATES ISO 7010		ANSI Z535 / OSHA PLATES		MEANING
	Symbol	Code	Symbol	Code	
1		ISO 7010 M002	 <p>Read and understand operator's manual before using this machine. Failure to follow operating instructions could result in death or serious injury</p> <p>Lire et comprendre le manuel de l'utilisateur avant d'utiliser cette machine. Ne pas suivre les instructions d'utilisation peut entraîner la mort ou des blessures graves</p>	UL001	Indicates a mandatory requirement for the operating personnel in charge of running the machine/plant and for the maintenance personnel to fully read and understand the instruction manual provided before performing any operating activity on the machine/plant. This obligation applies to the entire documentation provided with the machine as indicated in chapter 9 of this manual. Failure to comply with the operating instructions could result in death or serious injuries.
2		ISO 7010 M003	 <p>WARNING Wear ear protection</p> <p>AVERTISSEMENT Protection auditive obligatoire</p>	UL002	Danger loud noise with risk of injury for the user. It is mandatory to wear ear protection. Pay the utmost attention where this symbol is present.
3		ISO 7010 M014	 <p>WARNING Wear head protection</p> <p>AVERTISSEMENT Port du casque obligatoire</p>	UL003	It is mandatory for the user to wear head protection. Pay the utmost attention where this symbol is present.
4		ISO 7010 M009	 <p>WARNING Wear protective gloves</p> <p>AVERTISSEMENT Port des gants obligatoire</p>	UL004	It is mandatory for the user to wear protective gloves. Pay the utmost attention where this symbol is present
5		ISO 7010 F001	 <p>FIRE EXTINGUISHER EXTINCTEUR D'INCENDIE</p>	UL005	Location of fire extinguisher
6		ISO 7010 E003	 <p>EMERGENCY URGENGE</p> <p>First aid kit inside Trousse de premier soins</p>	UL006	Location of first aid box
7		CE007	 <p>WARNING Failure to read and understand operator's manual & all safety signs could result in serious injury. Manual must remain with machine</p> <p>AVERTISSEMENT Ne pas lire et comprendre le manuel de l'opérateur et tous les signes de sécurité pourrait entraîner des blessures graves. Le manuel doit rester avec la machine</p>	UL007	Indicates the position of the use and maintenance manual and prescribes the obligation to keep the manual together with the machine
8	 	ISO 7010 W012 CE008	 <p>DANGER Hazardous voltage Disconnect power before servicing or cleaning</p> <p>DANGER Tension dangereuse Débrancher l'alimentation avant de procéder à l'entretien ou au nettoyage</p>	UL008	Indicates dangerous voltage with risk of injury, even fatal, for the user. Pay the utmost attention to the areas where this signal is present and do not access them unless previously de-energised.

Ref.	PLATES ISO 7010		ANSI Z535 / OSHA PLATES		MEANING
	Symbol	Code	Symbol	Code	
9		ISO 7010 W024	 <p>WARNING Moving parts can crush and cut. Keep hands away from moving parts.</p> <p>AVERTISSEMENT Les pièces mobiles peuvent écraser et couper Garder les mains à l'écart des pièces mobiles</p>	UL009	Indicates a danger with risk of injury for the user. Keep your hands away from moving parts as they can cause crushing and cuts. It is mandatory to wear adequate clothing such as anti-cut gloves, shoes, work overalls, etc. Pay the utmost attention to the signs and areas where this symbol is present.
10		CE010	 <p>WARNING Point of clamp Use only appropriate handling systems</p> <p>AVERTISSEMENT Point de serrage Utiliser uniquement des systèmes de manutention appropriés</p>	UL010	Indicate the clamping points of steel chains or cables with hooks. Indicates a requirement on the equipment to be used. Pay attention to these plates and only use permitted lifting/handling systems using cranes and/or overhead cranes with adequate capacity.
11		ISO 7010 W002	 <p>DANGER Hazardous chemicals located within this enclosure</p> <p>DANGER Produits chimiques dangereux situés dans cette enceinte</p>	UL011A	Indicates a danger with risk of injury for the user. Dangerous chemical substances located within this perimeter. Refer to the instructions provided with the battery and affixed to it.
		ISO 7010 W002	 <p>DANGER Explosion hazard Do not operate in the presence of explosive atmospheres</p> <p>DANGER Risque d'explosion Ne pas opérer en présence d'atmosphères explosives</p>	UL011B	Indicates a danger with risk of injury for the user. Explosion hazard Do not operate in the presence of explosive atmospheres. Refer to the instructions provided with the battery and affixed to it.
		ISO 7010 W021	 <p>DANGER Risk of fire Do not use combustible or flammable materials in this area</p> <p>DANGER Risque d'incendie. N'utilisez pas de matériaux combustibles et inflammables dans cette zone</p>	UL011C	Indicates a danger with risk of injury for the user. Risk of fire. Do not use combustible or flammable materials in this area. Refer to the instructions provided with the battery and affixed to it.
		ISO 7010 M004	 <p>WARNING Risk of eye injury Eye protection required</p> <p>AVERTISSEMENT Risque de blessure aux yeux Lunettes de protection obligatoires</p>	UL011D	It is mandatory for the user to wear eye protection. Refer to the instructions provided with the battery and affixed to it.
12		CE012	 <p>WARNING Exposed moving parts can cause severe injury LOCK OUT POWER Before removing guard</p> <p>AVERTISSEMENT Les pièces mobiles exposées peuvent causer des blessures graves VERROUILLER L'ALIMENTATION Avant d'enlever la garde</p>	UL012	Indicates a danger with risk of injury for the user. Danger of dragging parts of the body. Do not use the machine without guards. Keep body, clothes, hair, tools and pipes away
13		ISO 7010 W017	 <p>CAUTION Burn hazard. Hot surfaces Do not touch</p> <p>ATTENTION Risque de brûlure Surfaces chaudes Ne pas toucher</p>	UL013	Indicates a danger with risk of injury for the user. Burn hazard. Hot surfaces. Do not touch.
14		CE014	 <p>WARNING Moving parts can crush and cut Do not operate with guard removed Follow lockout procedure before servicing</p> <p>AVERTISSEMENT Les pièces mobiles peuvent écraser et couper Ne pas utiliser avec la protection retirée Suivre la procédure de verrouillage avant l'entretien</p>	UL014	Indicates a hazard in area(s) with moving parts. Moving parts can cause crushing and cuts. Do not operate with guards removed. Follow lockout procedure before servicing

Ref.	PLATES ISO 7010		ANSI Z535 / OSHA PLATES		MEANING
	Symbol	Code	Symbol	Code	
15		CE 015	 WARNING CRUSH HAZARD Do not operate on moving parts AVERTISSEMENT RISQUE D'ÉCRASEMENT Ne pas utiliser sur des pièces mobiles	UL015	Indicates a prohibition for the user to lubricate and/or service machine/plant with moving parts. It is strictly forbidden to operate the machine without the guards supplied with the machine. Follow lockout procedure before servicing
		CE 015A	 WARNING CRUSH HAZARD Do not operate with guard removed AVERTISSEMENT RISQUE D'ÉCRASEMENT Ne pas utiliser avec la garde enlevée	UL015A	
16		CE016		UL016	Indicates a danger with risk of injury for the user. It is mandatory to keep a safe distance from the action range of the operating machine on which the equipment is installed. Pay the utmost attention to the signs and areas where this symbol is present
17		CE017	 NOTICE Battery master switch AVIS Interrupteur principal de batterie	UL017	Indicates the position of the battery cut-out
18		CE018	 NOTICE Diesel Tank ULSD fuel only AVIS Réservoir de diesel ULSD carburant seulement	UL018	Indicates the position of the diesel tank
19		CE019	 NOTICE Oil Tank AVIS Réservoir d'huile	UL019	Indicates the position of the hydraulic oil tank
20		ISO 7010 P011	 WARNING Do not use water on electrical equipment AVERTISSEMENT Ne pas utiliser d'eau sur un équipement électrique	UL020	Indicates a prohibition to use or direct water jets towards electrical equipment and, in any case, in all areas where this sign is present.
21		ISO 7010 P007A	 WARNING MAGNETIC FIELD Pacemakers wears are not allowed in this area AVERTISSEMENT CHAMP MAGNÉTIQUE Porteurs de pacemakers ne sont pas autorisés dans cette zone	UL021	Strong magnetic field present. Prohibition for pacemaker wearers to enter this area.
		ISO 7010 P007B			
22		ISO 7010 M005	 DANGER Connect Earth to Ground DANGER Connecter la mise à la terre	UL022	Indicates a mandatory requirement for the operating personnel in charge of running the machine/plant to connect the earthing, as indicated in the use and maintenance manual, before turning on the machine/plant.
		IEC 60417-5019	 DANGER Connection point earthing DANGER Point de connexion mise à terre	UL022A	Indicates the position of connection earthing

Ref.	PLATES ISO 7010		ANSI Z535 / OSHA PLATES		MEANING
	Symbol	Code	Symbol	Code	
23		CE023	 <div style="display: inline-block; vertical-align: middle; text-align: center;"> <div style="background-color: #0056b3; color: white; padding: 2px;">NOTICE</div> <div style="background-color: white; color: #0056b3; padding: 2px;">Greasing Points</div> <div style="background-color: #0056b3; color: white; padding: 2px;">AVIS</div> <div style="background-color: white; color: #0056b3; padding: 2px;">Point de graissage</div> </div>	UL023	Indicates the position of the greasing points
24		CE024A	 <div style="display: inline-block; vertical-align: middle; text-align: center;"> <div style="background-color: #ff8c00; color: white; padding: 2px;">WARNING</div> <div style="background-color: white; color: #ff8c00; padding: 2px;">Pressurized Hydraulic Oil Discharge pressure before maintance</div> <div style="background-color: #ff8c00; color: white; padding: 2px;">AVERTISSEMENT</div> <div style="background-color: white; color: #ff8c00; padding: 2px;">Huile hydraulique sous pression Décompresser avant la maintenance</div> </div>	UL024A	Indicates a danger with risk of injury for the user. It is mandatory to wear adequate shoes, work overalls, face shields, gloves, etc. In case of maintenance, make sure to have firstly discharged all hydraulic energy, paying attention that there are no uncontrolled movements of the actuators.
		CE024B	 <div style="display: inline-block; vertical-align: middle; text-align: center;"> <div style="background-color: #ff8c00; color: white; padding: 2px;">WARNING</div> <div style="background-color: white; color: #ff8c00; padding: 2px;">Pressurized Hydraulic Oil Discharge pressure before maintance</div> <div style="background-color: #ff8c00; color: white; padding: 2px;">AVERTISSEMENT</div> <div style="background-color: white; color: #ff8c00; padding: 2px;">Huile hydraulique sous pression Décompresser avant la maintenance</div> </div>	UL024B	
25		ISO 7010 M028		UL025	Indicates the position of safety lock of battery cut out and magnetotermich switches in main switchboard

The graphic representations and size of the stickers described are not binding.
The sizes of the examples are not in scale and are not the real ones.

1.3 WARNINGS FOR THE PURCHASER

The manual, like the CE certificate of conformity, is an integral part of the machine and must always accompany it in its every move or resale. The user is responsible for keeping this documentation intact, to enable consultation, throughout the life-span of the machine itself and always make it available to the operator and/or maintenance personnel.

In case of loss or destruction, a copy can be requested from the manufacturer, specifying the exact model, serial number and year of production.

The manual of the supplied product reflects the state-of-the-art at the time of supply. The writing company reserves the right to make any changes it deems useful to its products, without having to update the manuals and machines related to previous production lots.

The Manufacturer declines all liability for production anomalies and damages caused by the machine to property, persons and animals in the following cases:

- Improper use of the machine/plant or with different functions from those for which it was built.
- Electrical, hydraulic, fluidic, etc. supply defects.
- Failure to comply with the technical power supply specifications given in this manual.
- Use in environmental operating conditions other than those indicated in the safety chapter.
- Incorrect installation on the site or place for which it is intended.
- Unsuitable product supply.
- Insufficient or lack of periodic maintenance.
- Changes or interventions not agreed with and/or authorised by the manufacturer.
- Use in environments other than those for which the machine/plant was built.
- Use of non-original spare parts or not specific for the model.
- Use by unsuitable, unauthorised, uneducated and untrained personnel.
- Use by persons under the age of 18.

- Use by appointed personnel not adequately trained and informed as provided by Italian Legislative Decree 81/2008 and subsequent amendments and additions (Directive 89/391/CE or Directive 2009/104/EC) on the safety of workplaces.
- Use non-compliant with the laws on machine safety and/or safety regulations provided by the specific European and/or national laws in force.
- Total or partial failure to comply with these instructions.
- Exceptional events.

The user is responsible for applying the safety requirements given below and must make sure that the authorised personnel:

- Is qualified to perform the required activity
- Knows and strictly observes the instructions contained in this document
- Knows and applies the general safety regulations applicable to the machine/plant and those in force in the site of use.
- knows the safety regulations related to risks deriving from the treatment of products to which the machine/plant is destined.

It is mandatory for the technical maintenance personnel to have read and understood this manual and the documentation indicated in the Annexes chapter that is an integral part of it, know and have the basic principles of mechanics, electricity, oil hydraulics and know the connection, wiring practices and the symbols used in the wiring, mechanical and fluidic diagrams and is experienced in the use of equipment and machinery.

Failure to comply with the safety regulations can cause personal injuries and damage the machine/plant control units and components.

Reading, albeit exhaustive, this manual cannot under any circumstance replace an adequate experience of the operators.

The user can, at any time, contact the manufacturer to request further information in addition to that contained herein, as well as indicate improvement proposals.

NOTICE	
	PLEASE NOTE THAT THE DOCUMENTATION PROVIDED RELATES <u>ONLY</u> TO THE MACHINE SUPPLIED BY THE MANUFACTURER TO THE END USER.

 CAUTION	
	IMPROPER MACHINE USES AND INSTALLATION ENTAIL, IN ACCORDANCE WITH THE PROCESSING FEATURES, RISKS OF CONSIDERABLE ENTITY AND ARE PROHIBITED.

NOTICE	
	IT IS THE USER'S PRECISE RESPONSIBILITY TO INTEGRATE THESE INSTRUCTIONS WITH ANY OPERATING PROCEDURES PRESENT IN THE PLACE OF USE OF THE MACHINE AND PROVIDE THE MACHINE USE AND MAINTENANCE PERSONNEL ALL ADDITIONAL INFORMATION.

This manual is an integral part of the machine/plant to which it refers and contains the necessary information for:

- The correct sensitisation of operators with regard to safety;
- The safe handling/use of the machine/plant;

- The thorough knowledge of its operation and limits;
- Its correct use under safe conditions;
- Performing maintenance interventions correctly and safely;
- Safely dismantling the machine/plant in compliance with the applicable regulations to protect the health of workers and the environment.

Operators must be carefully trained on the operation and correct use of the safety devices installed.

NOTICE



THE MACHINE/PLANT MUST BE EXCLUSIVELY USED BY QUALIFIED OPERATORS AND TRAINED ON THE USE AND MAINTENANCE PROCEDURES AND MUST BE USED IN COMPLIANCE WITH THE RECOMMENDATIONS CONTAINED HEREIN.

The User is also responsible for ensuring that, if the manufacturer modifies this document, only the updated versions of the Manual are actually present in the places of use.

All manuals and the documentation referred to in chapter 9 are an integral part of this manual and for which the recommendations/requirements of this manual apply.

The machine must only be used to meet the requirements for which it was expressly conceived; any other use is considered dangerous and prohibited.

Any intervention modifying the structure and the cycle of operation of the machine must be expressly authorised by the technical department of the Manufacturer.

Only use original spare parts. The Manufacturer will not be liable for damages caused following the use of non-original spare parts.

The Manufacturer reserves the right to modify the project and make marketable improvements without notifying customers who already have similar models.

PROHIBITION TO MAKE CHANGES

It is forbidden to make changes to the machine which can reduce its safety; in particular, it is forbidden to remove or modify the guards and/or safety and/or signalling and/or control systems set-up by the Manufacturer.

Arbitrary changes to the machine to assemble special equipment exempt the manufacturer from any liability for damages that may be caused.

Interventions on the machine operating logic program are forbidden (even if carried out by qualified personnel); in fact even these interventions could have serious consequences for the safety of operators and integrity of the machine.

Please note that the Manufacturer's civil and criminal liability becomes void for the machine parts modified by the purchaser without the Manufacturer's express authorisation.

1.4 INTRODUCTION

In order to ensure maximum operating reliability, the manufacturer has carefully selected the materials and components to be used in the construction of the machinery, subjecting it to regular testing before delivery. Its good performance over time depends on the correct use and adequate preventive maintenance, according to the instructions in this documentation and in the documentation provided with the machine/plant.

All construction elements, connection and control parts have been designed and built with a degree of safety such to be able to withstand abnormal stresses or, in any case, higher than those indicated.

The materials are top quality and their introduction in the company and storage has been controlled, in order to ensure the absence of damages, deteriorations and malfunctions.

Despite the design and construction measures, it is of fundamental importance, for the correct use, safety, durability and reliability of the machine/plant, to scrupulously follow the manufacturer's instructions and install and use the same in compliance with these instructions and the legal requirements in force in the country/site of use of the machine/plant.

The purpose of this manual is to provide the personnel involved with the use and maintenance of the machine/plant with technical and operational information.

The instructions contained herein are addressed to operators with adequate knowledge in the electrical/electronic, mechanical and oil hydraulic field.

The instructions and warnings manual contains the information necessary for understanding the methods of installation, operation and correct use of the machine/plant, in particular: the technical description of the various functional units, safety systems and equipment, operation, use of the instrumentation and the interpretation of any diagnostic messages, main procedures and information relating to maintenance.

For a correct use of the machine/plant it is assumed and prescribed that the work environment complies with the current health and safety regulations.

NOTICE



BEFORE INSTALLING THE MACHINE/PLANT OR MAKING IT OPERATIONAL, USING IT OR SERVICING IT, CAREFULLY READ THIS MANUAL AND STRICTLY FOLLOW THE INSTRUCTIONS CONTAINED HEREIN.

It is also recommended for the above personnel to attend a training course in order to guarantee perfect familiarity and knowledge of the machine/plant.

1.5 MANUFACTURER'S DETAILS

INSTRUCTIONS FOR REQUESTING INTERVENTIONS

The machine/plant is a worldwide assisted product with direct coordination of the technical assistance by the manufacturer.

For any information or clarification on the installation, use, maintenance, etc. the writing company is always available to the user's requests.

The latter must ask questions in clear terms, with references to this manual and always indicate the data shown on the identification plate of the machine/plant.

Any request for information or intervention by the assistance service at the Customer premises or clarification regarding the technical aspects of this document, must be addressed to:



CAMS S.r.l.

Office and plant:

Via Giulio Golini, 301,

40024 Castel San Pietro Terme (BO) ITALY

Tel. +39 051 6946611 Fax. +39 051 6945650

www.camssrl.it

info@camssrl.it

In particular, the customer must provide the manufacturer with the following data:

- Machine/plant type, serial number, year of installation
- Found defects
- Exact address of the site/plant where the machine/plant is installed
- Contact person

1.6 SAFETY REGULATIONS IN THE MANUAL

The prescriptions, indications, regulations and relative safety notes described in the various chapters of the manual, are intended to define a series of behaviours and obligations to be followed in executing the various activities, in order to operate under safe conditions for personnel, equipment and surrounding environment.

The reported safety regulations are addressed to all authorised, trained personnel and delegated to perform the various activities and operations of:

- Transport
- Installation
- Operation
- Use
- Management
- Maintenance
- Cleaning
- Decommissioning and dismantling

which constitute the methods of use provided for the machine in question.



**FOR FURTHER INFORMATION ON TRAINING COURSES, SEE
CHAPTER 4 “SAFETY”.**



1.7 COMMISSIONING PROTOCOL

The machine will be provided with the document Commissioning Protocol, which must be filled out and signed.

CAMS Srl Via Giulio Golini, 30 - 40024 Castel S. Pietro (BO) Tel. +39 0516946611 Fax +30 0516946650 UFFICIO TECNICO - AFTER SALES SERVICE DEPARTMENT		MODULO DI CONSEGNA IMPIANTO PLANT COMMISSIONING PROTOCOL	
Cliente: Customer:		Via: Street:	
C.a.p./Città: ZIP Code/Town:		Stato: Country:	
Modello Impianto: Machine Type:		Matricola: Serial Number:	
<input type="checkbox"/> Impianto nuovo New Machine		<input type="checkbox"/> Impianto usato Used machine	
		Anno di costruzione: Year of construction	Ore impianto: Operating hours:
I seguenti punti devono essere spiegati e/o verificati in presenza dell'operatore: The following items were checked and/or explained in the presence of the owner/operator:			
A I seguenti punti devono essere verificati e/o discussi prima della messa in funzione: The following items were checked or discussed prior to start:			
1. Controllo della completezza rispetto all'ordine fatto dal cliente. <input type="checkbox"/> Check for completeness in accordance to the customer order.			
2. Controllo visivo di eventuali danni riportati durante il trasporto. <input type="checkbox"/> Visual check for transportation/sabotage damage.			
3. Completezza degli accessori, denti, chiavi e documentazione. <input type="checkbox"/> Completeness of accessories, tools, keys and documentation.			
4. Controllo dei dispositivi di sicurezza, delle targhe monitorie e dei rischi residui in riferimento a quanto indicato nel manuale di uso e manutenzione. <input type="checkbox"/> Control of safety devices, warning plates and residual risks with reference to the indications in the use and maintenance manual.			
B I seguenti punti devono essere verificati e/o spiegati dopo la messa in funzione : The following items were checked and or explained after starting-up :			
1. Spiegazione della posizione dell'operatore per la sua sicurezza, comandi e strumenti. <input type="checkbox"/> Explanation of operator's stand for his safety, controls and instruments.			
2. Spiegazione del display: Marcia/arresto, reset, spie di emergenza. <input type="checkbox"/> Explanation of display: Start/Stop, reset, warning lights .			
3. Controllo assenza di perdite. <input type="checkbox"/> Checking for leaks.			
C L'operatore è stato istruito, aiutato dal manuale di funzionamento, su quanto segue: The owner/operator was instructed, aided by the instructions manual as follows:			
1. Intervento emergenze, prova di messa a terra e presenza ed efficienza dei carter di sicurezza come elencato al paragrafo "Dispositivi di sicurezza" <input type="checkbox"/> Intervention emergencies, grounding test and presence and efficiency of the safety carter as listed in the paragraph "Safety devices"			
2. Presenza degli adesivi di avvertenza come elencato al paragrafo "Targhette e segnalazioni" <input type="checkbox"/> Presence of warning stickers as listed in the paragraph "Targets and signals"			
3. Comprensione dei paragrafi: Rischi residui - Uso previsto - Uso non consentito - Predisposizioni a carico dell'utilizzatore <input type="checkbox"/> Understanding the paragraphs: Residual risks - Proper use - Prohibited use - Predispositions charged to the user			
4. Comprensione modalità di funzionamento <input type="checkbox"/> Understanding mode of operation			
5. Punti e periodi di lubrificazione, tipi di grasso come indicato nel manuale di uso e manutenzione. <input type="checkbox"/> Lubrification points and intervals, grease types accordance to instructions manual.			
D Commenti/Comments			
Con la presente si certifica che l'impianto in oggetto è stata consegnato in condizioni soddisfacenti, che il manuale di uso e manutenzione è stato consegnato e che sono state date tutte le istruzioni di uso e manutenzioni dell'impianto incluso i dispositivi di sicurezza. It is hereby certified that the above mentioned machine was handed over in satisfactory condition, that the instructions manual was handed over and the instructions in operating and service of the machine, including its safety regulations, were given.			
		Cliente - Customer	Venditore - Dealer
Nome: Name:			CAMS service engineer
Firma: Signature:			
Data: Date:			

1.8 GLOSSARY OF THE TERMS USED

Technical terminology is used in the manuals or with different meaning from the common.

The terms and abbreviations used are explained below:

HAZARD: (Annex I, 1.1.1 Directive 2006/42/EC).
 potential source of injury or damage to health;

DANGEROUS AREA: (Annex I, 1.1.1 Directive 2006/42/EC).
 any area inside and/or near the machine/plant where the presence of an exposed person constitutes a health and safety risk for that person;

EXPOSED PERSON: (Annex I, 1.1.1 Directive 2006/42/EC).
Any person wholly or partially inside a hazardous area;

RISK: (Annex I, 1.1.1 Directive 2006/42/EC).
combination of probabilities and severity of an injury or health hazard that may arise in a dangerous situation;

GUARD: (Annex I, 1.1.1 Directive 2006/42/EC).
element of the machine/plant used specifically to ensure protection by means of a physical barrier;

PROTECTION DEVICE: (Annex I, 1.1.1 Directive 2006/42/EC).
device (other than a guard) that reduces the risk, on its own or associated with a guard;

INTENDED USE: (Annex I, 1.1.1 Directive 2006/42/EC).
machine/plant use in compliance with the information provided in the operating instructions;

IMPROPER USE:
use of the machine/plant different from that indicated in the operating instructions, but which may derive from the easily predictable human behaviour;

RESIDUAL HAZARD:
hazard that could not be eliminated or reduced by design, against which the protections are not (partially or totally) effective;

The Manual (Safety Chapter) indicates the residual risks and information, instructions and warnings/requirements for managing the Residual Risks that must be borne by the user (Ref. EN ISO 12100:2010).

For a complete description of the terminology used, please refer to the definitions given in Annex I of Machinery Directive 2006/42/EC and in Standard EN ISO 12100:2010.

PERSONAL PROTECTIVE EQUIPMENT (PPE):
Personal protective equipment means any equipment intended to be worn and/or used by the worker in order to protect him/her from one or more risks likely to threaten health or safety during work, as well as any element or accessory intended for that purpose.

The following is not personal protective equipment:

- Ordinary work clothes and uniforms not specifically designed to protect the worker's health and safety;
- The equipment of the first aid and rescue services;
- The personal protective equipment of armed forces, police forces and service personnel for the maintenance of public order;
- The personal protective equipment for road transport;
- Sport materials;
- Self-defense or deterrence materials;
- Portable devices to identify and report risks and harmful factors.

USER:

It is considered user (entrepreneur/company) who uses the machine for the intended use, or entrusts its use to competent persons and specially trained for the purposes of the intended use for this type of machine/plant.

MAN-MACHINE INTERACTION

Any situation in which an operator interacts with the machine in any of the operating phases at any time in the life-span of the same.

MACHINE STATUS:

The machine/plant status includes the operating mode, for example automatic start, hold-down control, stop, etc., the condition of the safety devices on the machine/plant such as protectors included, protectors excluded, pressed emergency stop, type of insulation of energy sources, etc.

EMERGENCY STOP

Device that, in case of emergency, suddenly locks all machine components by performing a category "0" stop of all actuators. It is not a normal shutdown operation.

TRACKED CARRIAGE

This is a structure normally made up of beams formed by a carriage, rollers, slides and wheels that slide and transmit motion to the machine.

PROTECTIVE GUARD

This is a guard that can be fixed or mobile and which normally consists of a cover, barrier, net, gate or similar used to prevent contact with moving parts.

CYLINDER UNIT – SECONDARY SHREDDER - CTR

Secondary shredder unit with respect to the main crushing unit. It consists of two counter-rotating shafts with crushing teeth. It may also be referred to as Secondary crushing unit, secondary shredder or CTR.

ARMOR PLATE

Interchangeable tool or permanently welded to the structure, used to crush the material to be processed.

WIRE CONTROL

Command and control system for the machine functions made up of a device wired to the machine via an electrical communication cable.

MILLING CUTTER

Metal disk upon which tools suitable for crushing the processed material are mounted.

GREASERS

Distributors of lubrication grease situated in points containing moving or rotating parts that are easily accessed to insert the lubricant.

ENGINE-GENERATOR UNIT

This is the power unit of the machine/plant and it consists of the coupling of an endothermic motor and an alternator and is used to power all machine actuators/components.

SCREEN FEED CONVEYOR - MAIN CONVEYOR

Conveyor with an endless belt that acts as transport and traction element. The belt is supported by rollers and slides on a surface and is used to handle the crushed material from the crusher to the screen.

CONVEYOR BELT UNDER CYLINDER UNIT

It is a conveyor belt used to transfer the material from under the cylinder unit to the recirculation conveyor.

FINE CONVEYOR

Conveyor that collects and handles the material that has been screened and therefore passed all screening stages in the machine and is thus conveyed towards the product outfeed or accumulation area (fine sized material).

INTERMEDIATE CONVEYOR - SIDE CONVEYOR

Conveyor that collects and handles the material that has been screened by the first screening net and that conveys it towards the product outfeed or accumulation area (medium sized material).

RECIRCULATION CONVEYOR

Conveyor that carries the material that has not crossed any screening net and that is recirculated for the purpose of the production process (closed cycle) or sent to accumulation (open cycle) according to the customer needs.

ELECTRICAL CONTROL PANEL

This is a casing containing the power and command part and which protects the electrical equipment against any external influences and against direct contact from any direction.

REMOTE CONTROL

Command and control system for the machine functions made up of a device with radio wave operation without connection directly wired to the machine.

BELT SCRAPER

Fixed or mobile device installed along the entire length of the belt in line with the conveyor drums. This is used to remove any material that may build-up on the belt.

RETURN ROLLERS

They are idle return rollers assembled under the conveyor belt to support it.

SIDE HOPPER EXTENSIONS

Metal bulkheads designed to increase the volume of the loading hopper

HYDRAULIC FINGERS - PUSHER

Mechanical elements hinged to the product loading hopper structure and driven by double-acting hydraulic jacks that are used to ensure continuous feeding of the crusher, thus avoiding temporary lack of product following a "bridge effect" due to the overlapping of material or similar situations.

SUPPORTING ROLLERS

They are assembled on the upper part of the conveyor to create an arch with the belt in order to prevent material spilling.

TAIL DRUM

Idle metal cylinder where the rubber conveyor belt winds. It is situated in the rear part of the conveyor which is also called tail drum.

MOTOR DRUM

Motorised metal cylinder that transmits motion to the rubber conveyor belt winds. It is situated in the front part of the conveyor which is also called head drum.

BELT

Rubber material conveyor belt, hot vulcanised, closed loop that connects the tail drum with that of head.

PRE-BREAKER BAR

Mechanical part located centrally under the two crusher shafts is used to contrast the outfeed material, whose vertical position can be adjusted to vary the output size of the processed product.

FRAME

Bearing structure composed of metal bolted or welded profiles that connect all components forming part of the machine/plant.

FEED HOPPER

Inverted pyramid trunk or funnel-shaped container made of folded and welded sheet steel, which contains the material loaded for crushing.

CONVEYOR BELT

Product handling system that can be horizontal, tilted or vertical and transports and handles the processed material.

(This is a generic definition used to describe one of the types of conveyor belt specified above)

CRUSHING UNIT - PRIMARY SHREDDER - FTR

Primary crushing machine that processes the infeed material, also called crusher, shredder or FTR.

SCREENING UNIT





Vibrating machine consisting of a net screen and vibrating unit used to separate the material according to its size.

This manual uses the term operator or appointed personnel meaning the person(s) authorised to install, commission, use, operate and service the machine in compliance with the following classification.

In this manual the term machine, as defined in art.2 of Machinery Directive 2006/42/EC, crusher or plant are used as a synonym.

1.9 PERSONNEL QUALIFICATION

The symbols listed in the table are used in the Manuals, next to the notes in bold to indicate important information/requirements regarding the professional qualification required.

<i>Symbol</i>	<i>Description</i>
	<p>OPERATOR User personnel trained and authorised to use and run the machine for the purpose of handling and production for the activities for which it was built and supplied. The operator must be able to perform all operations necessary for the proper operation of the machine and personal safety, making sure that there are no third parties in the working area during the machine operation. The operator must have read and understood this entire manual, with particular reference to chapters 3 and 4 The operator must have proven experience in the correct use of these types of machines/plants and be trained, informed and instructed in this regard. In case of doubt, he/she must report any anomaly to their superior. He/she is not authorised to perform any maintenance activity.</p>
	<p>OPERATOR OF LIFTING AND HANDLING EQUIPMENT Personnel authorised to use the equipment for lifting and handling materials and machines (strictly following the manufacturer's instructions), in compliance with the laws in force in the country of use of the machine.</p>
	<p>MECHANICAL MAINTENANCE TECHNICIAN Qualified technician able to handle and run the machine as operator, intervene on mechanical parts for adjustments, maintenance, repairs and knows how to read the fluidic, oil hydraulic diagrams, technical drawings and listed spare parts. In extraordinary cases, is trained to operate the machine with reduced safety, implementing alternative safety systems to those present. He/she is not enabled to intervene on live electrical systems (if any). Where necessary, can give the operator instructions for the good use of the machine for production purposes.</p>
	<p>ELECTRICAL MAINTENANCE TECHNICIAN Qualified technician able to run the machine as operator, to intervene on the adjustments and on the electrical/electronic systems for maintenance, repair and replacement of worn pieces. Is able to read the wiring diagrams, verify the correct functional cycle. Can operate in the presence of voltage inside the electrical panels, junction boxes, control equipment, etc., only if suitable person (PEI) (See EN50110-1 and EN 50110-2). Where necessary, can give the operator instructions for the good use of the machine for production purposes.</p>
 Manufacturer	<p>MANUFACTURER'S TECHNICIAN Technician qualified by the manufacturer and/or its distributor and/or authorised by him for complex operations, because aware of the production cycle of construction of the machine/plant. This person intervenes in accordance with the user's requests. The skills are, depending on the case, mechanical and/or electrical and/or electronic and/or software.</p>

PROFESSIONAL FIGURES

1.10 DESCRIPTION OF THE PERSONAL PROTECTIVE EQUIPMENT (PPE)

The personnel in charge of running, use and maintenance who performs the various activities permitted on the machine must wear the personal protective equipment that allows the same to reduce all possible risks deriving from the execution of the various activities, such as:

- helmet to protect the head
- accident-prevention goggles or mask to protect against splinters, dust or oil jets or residues deriving from the work process or maintenance operations.
- mask to protect against any fumes, inhalations, etc. deriving from the risk of the work cycles or maintenance operations.
- accident-prevention gloves, shoes and boots as required and according to the type of products used in the process in question.
- ear protectors

 **CAUTION**





















THE CLOTHING OF THOSE WORKING OR PERFORMING MAINTENANCE ON THE MACHINE MUST COMPLY WITH THE ESSENTIAL SAFETY REQUIREMENTS DEFINED BY THE COMMUNITY DIRECTIVES 89/656/CE AND 89/686/CE AND THE LAWS IN FORCE IN THE COUNTRY OF INSTALLATION OF THE SAME.

 **WARNING**



PROJECTION OF SPLINTERS OR MATERIALS
CAN DAMAGE THE EYES OR UNCOVERED PARTS OF THE BODY
USE SCREENS OR OTHER ADEQUATE SAFETY MEASURES.

PLATES ISO 7010		ANSI Z535 / OSHA PLATES		MEANING
Symbol	Code	Symbol	Code	
	ISO 7010 M014		UL003	It is mandatory for the user to wear head protection. Indicates a requirement for maintenance personnel to wear a protective helmet. PPE to always use when performing maintenance on the machine/plant or on the units.
	ISO 7010 M013		UL025	Indicates a requirement for personnel to use the protective screen. PPE to always use when performing maintenance on the machine or on its units. The use of the protective screen is prescribed in case of risk of projection of objects or material.
	ISO 7010 M004		UL011C	Indicates a requirement for personnel to wear the protective goggles. PPE to always use when performing maintenance and/or cleaning on the machine or on its units. The use of goggles is prescribed in case of risk of projection of objects or material.

PLATES ISO 7010		ANSI Z535 / OSHA PLATES		MEANING
Symbol	Code	Symbol	Code	
	ISO 7010 M003		UL002	Indicates a requirement for personnel to wear earmuffs or caps to protect hearing. PPE to always use when operating with the machine and/or in the processing site or during maintenance.
	ISO 7010 M009		UL004	Indicates a requirement for personnel to wear protective and insulating gloves. PPE to always use when operating with the machine and/or in the processing site or during maintenance.
	ISO 7010 M008		UL026	Indicates a requirement for personnel to wear protective footwear. PPE to always use when operating with the machine and/or in the processing site or during maintenance.
	ISO 7010 M017		UL027	Indicates a requirement for personnel to wear masks to protect the respiratory tracts. PPE to always use when performing cleaning on the machine/station. PPE to use also in case of use of thinners or other cleaning detergents.
	ISO 7010 M018		UL028	Indicates a requirement for personnel to wear seat belts and adequate means for all work to be performed at a height or in positions not directly reachable from the ground. PPE to always use when operating with the machine and/or in the processing site or during maintenance in case of positions not directly reachable from the ground. In this case, make sure that any ladders or platforms, etc. comply with the legal provisions in force and provided for such means.
	ISO 7010 M010		UL029	Indicates a requirement for personnel to wear appropriate and protective work clothes. PPE to always use when operating with the machine and/or in the processing site or during maintenance.

NOTICE



THE PPE INDICATED HERE MUST BE INTEGRATED BY THE USER IN ACCORDANCE WITH THE WORK SITE (TYPE AND MATERIAL TO BE PROCESSED, ETC.) WITH THE PRESCRIBED REQUIREMENTS AND IN ACCORDANCE WITH THE PROVISIONS IN FORCE IN THE COUNTRY OF USE.



THE DETAILED DESCRIPTION OF THE “PICTOGRAMS” AND “PPE” PROVIDED, SPECIFIC FOR THE SUPPLIED MACHINE, IS DESCRIBED IN THE VARIOUS CHAPTERS IN THIS MANUAL. SAID PARAGRAPH ONLY LISTS AND EXPLAINS THE MEANINGS OF THE “PICTOGRAMS” AND “PPE”.



1.11 MANUAL LANGUAGE



The original manual was written in Italian and translated into the language of the end user and indicated on the cover of the manual.

Any translations into additional languages are borne by the customer and must be made starting from the original instructions.

The manufacturer is responsible for the information contained in the Original instructions. Translations into different languages cannot be completely verified, so if an inconsistency is detected it is necessary to respect the text in the original language or contact our Technical Documentation Department.

1.12 WARRANTY

In constructing the machine, the Manufacturer has used materials of the type and quality deemed, at their sole discretion, suitable for the machine.

Even after commissioning, the Manufacturer will be able to make changes which, at their sole discretion, constitute improvements.

The Manufacturer warrants the machine and equipment free from material or processing defects for the period indicated in the contract stipulated with the purchaser/customer.

During this period, the Manufacturer undertakes to eliminate evident vices and/or defects found by the purchaser/customer within the necessary time. The defective components, excluding wear parts, will be replaced free of charge during the warranty period, without prejudice to the travel and shipping costs.

Finally, the transport, inspection, assembly and re-assembly due to the intervention of the Manufacturer technician are excluded from the warranty, if the found vices and/or defects are not covered by this warranty.

This warranty is only applied to the purchaser compliant with the contractual regulations and if the installation, use of the machine and equipment are performed by the purchaser in accordance with the instructions contained in this manual.

The Manufacturer will not be liable for faults or malfunctions if there are deficiencies in maintenance, lack of lubrication, replacement of non-original machine parts or not authorised and use of the machine differently from that indicated in this instruction manual. This warranty does not extend to replaced or repaired parts and to all parts that are subject to wear due to their specific use.

Any further obligation and/or compensation and/or indemnity by the Manufacturer remains expressly excluded

The warranty excludes any and all liability for direct or indirect damages to persons and property arising from the incorrect or incomplete installation, incorrect use and inadequate maintenance of the machine. Partial or total failure to comply with the legal provisions in force in the country of use of the supplied machine.

We do not accept returns of goods unless authorised by the Manufacturer and carriage paid.

The complete warranty clauses are set out in the sales contract.

The warranty is subject to the following conditions:

- The machine must be used within the limits stated in the “Technical data” section of this manual;
- The machine must be used following the instructions in this manual;
- Maintenance must be performed within the times and methods provided by the maintenance manual, using original spare parts and entrusting the interventions to qualified personnel.

NOTICE

THE ACTIVATION OF THE WARRANTY IS SUBJECT TO THE RETURN OF THE DELIVERY FORM DULY COMPLETED AND SIGNED.

A COPY OF THIS DELIVERY FORM IS PROVIDED WITH THE “CE” DECLARATION OF CONFORMITY OF THE MACHINE

THE NON-RETURN OF THE DELIVERY FORM DULY COMPLETED AND SIGNED DOES NOT ALLOW THE MANUFACTURER TO ACTIVATE THE WARRANTY FOR THE PURCHASED MACHINE.

THEREFORE, IN THE INTEREST OF THE PURCHASER, IT IS ESSENTIAL FOR THIS FORM TO BE RETURNED COMPLETED AND SIGNED AND SENT BY MAIL OR E-MAIL TO THE MANUFACTURER.



1.13 MACHINE/PLANT MANAGEMENT

The machine/plant can only be managed by authorised personnel, appropriately trained or at least provided with sufficient knowledge and technical experience.

Personnel in charge of running and servicing the machine must be aware that the knowledge and application of the safety regulations is an integral part of their work.

NOTICE

UNAUTHORISED PERSONNEL MUST NOT HAVE ACCESS TO THE OPERATING AREA OF THE MACHINERY AND TO THE CONTROL SYSTEM.



In particular, the User is responsible:

- That the installation site be in compliance with the regulatory provisions in force in the country of use.
- For the verification and arrangement of the passage, escape routes and the operational and maintenance spaces necessary all around the machine.
- For carefully reading this manual and the manuals indicated in chapter 9.

- For knowing which protections, safety devices and emergency stop devices are present on the machine/plant, the relative location and operation.

 **CAUTION**



THE DISCONNECTION OR PARTIAL REMOVAL OF THE SAFETY DEVICES AND PROTECTIONS OF THE DANGEROUS PARTS IS FORBIDDEN. THE SAME STANDARD APPLIES TO THE SIGNALS (WARNING, DANGER, PROHIBITION, WARNING, ETC. PLATES). IT IS STRICTLY FORBIDDEN TO OPEN THE PANELS OR THE CONTROL AND POWER UNITS DURING OPERATION OR IMMEDIATELY AFTER THEIR SWITCH-OFF. IT IS FORBIDDEN TO ACCESS THE AREAS MARKED BY APPROPRIATE WARNING PICTOGRAMS WITHOUT THE ADEQUATE PPE INDICATED AND PRESCRIBED.

 **CAUTION**



THE SAFETY DEVICES AND PROTECTIONS MUST BE KEPT PERFECTLY EFFICIENT IN ORDER TO ENABLE THEIR CORRECT OPERATION. IN CASE OF FAULT OR MALFUNCTION, THEY MUST BE IMMEDIATELY REPAIRED OR REPLACED.

 **CAUTION**



THE UNAUTHORISED USE OF COMMERCIAL PARTS AND ACCESSORIES WHICH ARE PART OF THE SAFETY DEVICES AND PROTECTIONS CAN CAUSE MALFUNCTIONS AND THE ARISING OF DANGEROUS SITUATIONS FOR THE OPERATING PERSONNEL.

NOTICE



THE VARIOUS SAFETY SYSTEMS ARE IDENTIFIED IN CHAP. 4 "SAFETY".