

APR™ 850-25

TABLE OF CONTENTS

1.1	PREMISE	3
1.1.1	Important warnings.....	4
1.1.2	General safety warnings.....	5
1.2	TESTING	9
1.3	WARRANTY	10
1.4	EXAMPLE OF EC DECLARATION OF CONFORMITY	11
1.4.1	EC Identification plate	12
1.5	REGULATORY REFERENCES	14
1.5.1	Directives and standards concerning the safety of the machines	14
1.6	ASSISTANCE	15

1.1 PREMISE

This manual relates to the APR™850-2s machine, self-propelled plant suitable for crushing and selecting materials as in paragraph 4.2

This manual is published by CAMS srl. Manufacturer of the machines and/or plant.
CAMS S.r.l. has the following business name:

CAMS S.r.l.
Via Giulio Golini, 301
40024 Castel San Pietro Terme BO Italy

Tel.+39 051694611

camsrecycling.com

E-mail info@camsrecycling.com



WARNING

An operator is not provided on-board the machine in question.



ATTENTION

Information on residual risks is given in paragraph 6.4

1.1.1 Important warnings

This manual provides information for the proper operation and maintenance of your self-propelled tracked crushing and screening plant hereinafter also called "machine" or "plant" or "APR™850-2s".

Read it carefully, UNDERSTANDING ITS MEANING before commissioning. During use operating personnel must be able to refer to it at any moment.

A copy of this manual must be kept together with the machine and made available upon the request of any operator. If ruined or illegible in any part, a copy must be immediately requested.

The Manufacturer declines any liability for improper use of the machine, for damages caused by operations not covered in this manual or unreasonable.

The machine must only be used to meet the requirements for which it was expressly conceived and which are detailed below; any other use is considered dangerous and therefore prohibited.

The Manufacturer is responsible for the machine only in its original configuration established during the design phase.

Any intervention modifying the structure and the cycle of operation of the machine must be expressly authorised in writing by the technical department of the Manufacturer.

Only use original spare parts. The Manufacturer will not be liable for damages caused following the use of non-original spare parts. This behaviour implies losing any form of warranty of the machine and of its components.

The Manufacturer reserves the right to modify the project and make technical improvements without notifying customers who already have similar models.

Preventive maintenance, with regard to deadlines and quality of spare parts prescribed by the manufacturer, represents the easiest form of maintenance and more convenient aimed at minimising machine downtime and sometimes very expensive failure of components. Follow the instructions in this chapter concerning maintenance work, where all necessary information can be found.

It is forbidden to confer or make available to third parties the drawings and technical documentation without our explicit written authorisation; all production rights of this manual are reserved to the Manufacturer.

This manual contains, by way of example, many illustrations and symbols that are not binding for the manufacturer.

The Manufacturer reserves the right to modify the project and make marketable improvements without notifying customers who already have similar models.

1.1.2 General safety warnings

This manual is delivered together with the machine, of which it is an integral part and must accompany it even in case of sale.

Keep this manual where the machine is installed in order to have it always at hand for consultation.

In addition to the instruction in the manual, all mandatory rules on safety, accident-prevention and environmental protection must be complied with.

The manual must be carefully read. It is necessary, upon commissioning of the crusher, that operators intended to use it attentively follow the first training and educational course held by the Manufacturer's technician and which covers the machine operation, the control procedures, the plant and personnel supervision, etc.

Failure to comply with the instructions in this manual, poor periodic maintenance or the precarious execution of the plant incorporating the machine, may lead to hazardous events for people and not easily predictable.

The work carried out on the machine or near it must be checked to ensure that the manual instructions have been strictly followed.



IMPORTANT

Should it be necessary to modify the calibrations of the hydraulic system or of the PLC according to values and settings not included in this manual, the site manager must request the manufacturer's authorisation and procedure of intervention.

Carry out inspections and maintenance interventions as instructed and in the periods indicated in the manual.

Always use the right instruments for the work to be performed

It is forbidden to remove or make illegible any danger symbols or safety indications (decals) placed on the machine.

Replace decals if they are no longer legible or missing; any detached or damaged decals can be obtained from your local dealer.

The fire extinguishers must be made available by the site manager and located near the crusher in order to quickly act in case of a fire. Two 6 kg extinguishers are sufficient.

The procedures in case of fire must be strictly followed.



HAZARD

Before using the machine or before maintenance, read and understand the manual and those provided with the machine and familiarise yourself with the controls and understand the safety and danger warnings on the machine itself.

Despite APR™850-2s, like all machines produced by the Manufacturer, is equipped with safety devices designed for a safe use, the operator must always use the machine consciously and strictly respect the manufacturer's requirements who is always the ultimate connoisseur of its products. A reckless and careless use may lead to serious damage of property or people and also irreparably jeopardise the machine components.

Installation, commissioning, use and routine maintenance interventions

can only be performed by people who have read and understood the technical documentation provided with the crusher.

Non-routine maintenance interventions can only be carried out by qualified personnel, authorised by the Manufacturer.

**WARNING**

Observe the current safety regulations with regard to accident-prevention and any other specific regulation applicable if recurring.



Never access the crushing shafts and other mobile parts of the machine without having first turned off the thermal motor of the crusher or disconnected the crusher and belt power supply cable, having waiting for moving parts to stop and removed the keys from the control board.



Place a sign on the ignition panel saying "DO NOT START, MAINTENANCE IN PROGRESS" to avoid others starting the machine without noticing that someone is carrying out checks or maintenance in places exposed to hazards deriving from the crusher's movements.



During operation of the crusher, the operator must move away anyone passing or standing within the dangerous area around the machine, as defined below!



The safety regulations contained in this manual and in those provided by the Manufacturer and the other standards applicable depending on the work place must be strictly observed. Different behaviours exempt the Manufacturer from any kind of liability.



IT IS FORBIDDEN TO MAKE ANY CHANGES TO THE CRUSHER unless authorised in writing in advance by the Manufacturer. Otherwise this would lead to losing the CE marking on the machine by the Manufacturer, exempting it from any kind of liability.

- APR™850-2s has been designed to work alone. Its inclusion in a plant implies that it is no longer referred to as "machine" but "part of machine" and that it must be re-evaluated within the new plant, with regard to the general safety of the plant itself.
- It is strictly forbidden to tamper with or remove the safety devices. Should one of these devices be damaged, it is forbidden to use the crusher. Immediately repair the damaged device and, should this not be possible, replace it with a new one. Please note that all of these operations must be performed in accordance with the safety procedures mentioned therein.
- Use only fluids and spare parts indicated by the Manufacturer.
- Before intervening on the machine make sure that the high temperature parts have cooled.
- Machine pieces above 20 kg must only be handled using adequate lifting equipment.
- The extraordinary maintenance operations may only be carried out by qualified technical personnel and authorised by the Manufacturer.
- Subject the machine to a check of the functionality of the safety device at least once a day

Accident-prevention standards

APR™850-2s has been designed to work alone. Its inclusion in a plant implies that it is no longer referred to as "machine" but "part of machine" and that it must be re-evaluated within the new plant, with regard to the general safety of the plant itself, by means of an attentive analysis of the risks.

Once the Manufacturer's technicians have commissioned the machine, it is equipped with all protections prescribed by the standards for the prevention of accidents at work. No operational need authorises anyone, not expressly appointed by the crusher's manufacturer, to make it work with these protections not regularly installed and in good condition.



HAZARD

IMPORTANT - Always earth the machine on the left side, using screw 1 (Fig. 1-1) pre-arranged in the rear area of the frame.

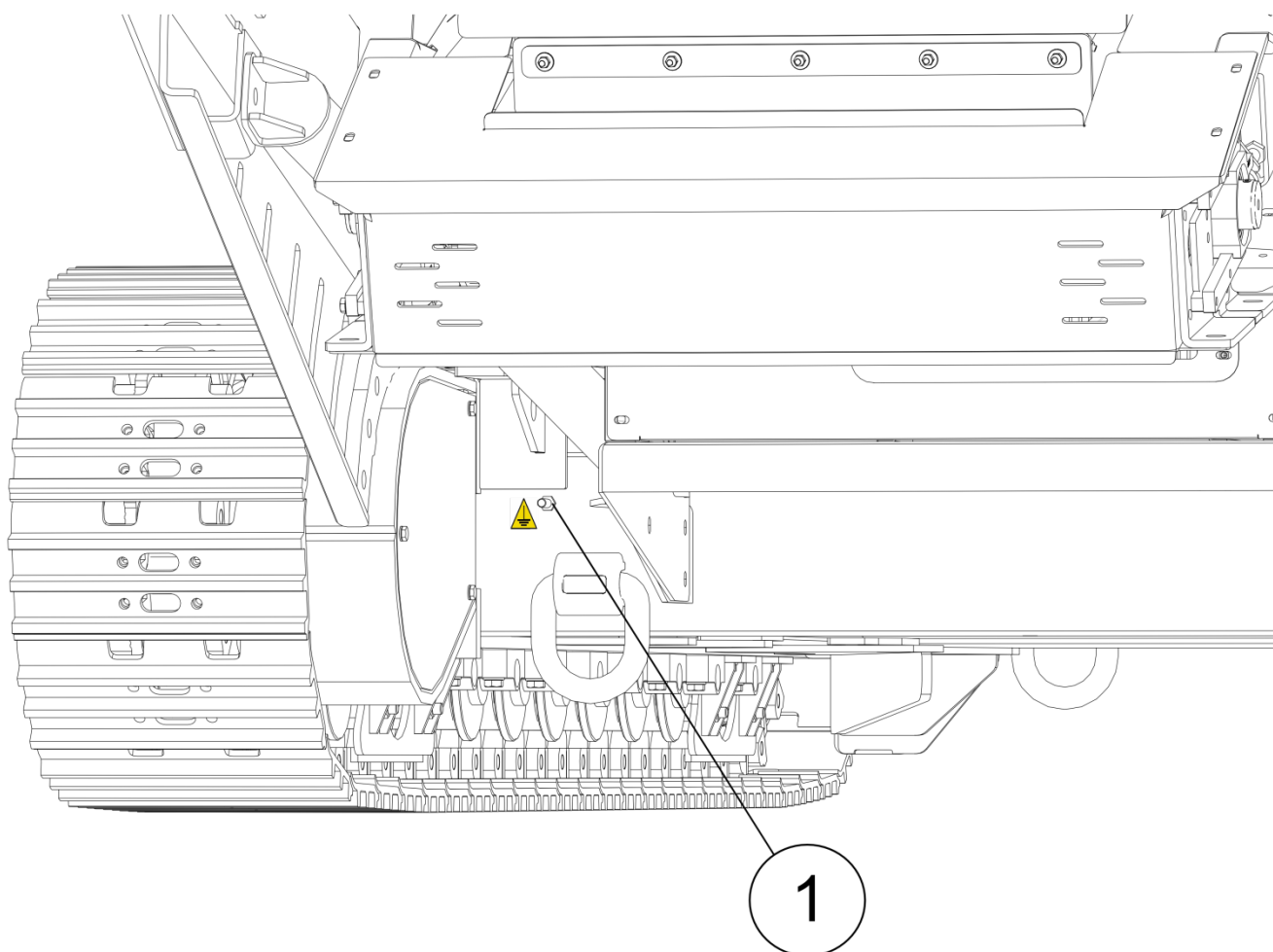

Fig. 1-1

**HAZARD**

Personal protective equipment

**HAZARD**

Personnel working on or near the machine, even if not transiting or standing inside the dangerous area as defined in this manual, must at least wear the following personal protective equipment (PPE):

- earmuffs or equivalent devices;
- gloves;
- high shoes above the ankle.
- protective goggles

All of the above devices must be approved for accident-prevention purposes.

Safety symbols

Stickers are present on the machine to recall the attention of operators and of those at the construction site on the presence of hazards that the manufacturer, due to the nature of the machine, could not eliminate. These are "residual risks"; below is a diagram of the position of these stickers.

It is forbidden to remove or make illegible any danger symbols or safety indications (decals) placed on the machine.

Replace decals if they are no longer legible or missing; any detached or damaged decals can be obtained from your Manufacturer's local dealer.

1.2 TESTING

CAMS Srl Via Giulio Golini, 30 - 40024 Castel S.Pietro (BO) Tel. +39 0516946611 Fax +30 0516946650 UFFICIO TECNICO - AFTER SALES SERVICE DEPARTMENT	MODULO DI CONSEGNA COMMISSIONING PROTOCOL		
Cliente: Customer:	Via: Street:		
C.a.p./Città: ZIP Code/Town:	Stato: Country:		
Modello macchina: Machine Type:	Matricola: Serial Number:		
? Macchina nuova New Machine	? Macchina usata Used machine		
	Anno di costruzione: Year of construction		
	Ore Macchina: Operating hours:		
I seguenti punti devono essere spiegati e/o verificati in presenza dell'operatore: The following items were checked and/or explained in the presence of the owner/operator:			
A I seguenti punti devono essere verificati e/o discussi prima della messa in funzione della macchina: The following items were checked or discussed prior to start the engine:			
1. Controllo della completezza della macchina rispetto all'ordine fatto dal cliente. Check for completeness of the machine accordance to the customer order.	<input type="checkbox"/>		
2. Controllo visivo di eventuali danni riportati durante il trasporto. Visual check for transportation/sabotage damage	<input type="checkbox"/>		
3. Completezza degli accessori, denti, chiavi e documentazione. Completeness of accessories, tools, keys and documentation.	<input type="checkbox"/>		
4. Controllo dei dispositivi di sicurezza in riferimento a quanto indicato nel manuale di uso e manutenzione. Reference to safety regulations accordance to instructions manual.	<input type="checkbox"/>		
B I seguenti punti devono essere verificati e/o spiegati dopo la messa in funzione della macchina: The following items were checked and or explained after starting-up of the machine:			
1. Spiegazione e della posizione dell'operatore per la sua sicurezza, comandi e strumenti. Explanation of operator's stand for his safety, controls and instruments.	<input type="checkbox"/>		
2. Spiegazione del display: Marcia/arresto motore, marcia/arresto in ciclo automatico e manuale, reset, spia di emergenza. Explanation of display: Start/Stop engine, Start/Stop in automatic and manual cycle, reset, warning lights.	<input type="checkbox"/>		
3. Funzione dei dispositivi elettronici, idraulici e meccanici: Prove di traslazione/sterzata con radiocomando, marcia/arresto con radiocomando, apertura/chiusura nastri, alzare/abbassare vaglio, regolazione calamita. Function of electrical, hydraulic and mechanical devices: Translational/turn test with radio remote control, start/stop with radio remote control, open/close belt conveyors, raise/lower screen, regulation magnetic over belt.	<input type="checkbox"/>		
4. Controllo assenza di perdite. Checking for leaks	<input type="checkbox"/>		
C L'operatore è stato istruito, aiutato dal manuale di funzionamento su quanto segue: The owner/operator was instructed, aided by the instructions manual as follows:			
1. Controllo dei dispositivi e delle targhette di segnalazione e per la sicurezza. Device control and warning labels for the safety.	<input type="checkbox"/>		
2. Punti e periodi di lubrificazione, tipi di grasso come indicato nel manuale di uso e manutenzione. Lubrication points and intervals, grease types accordance to instructions manual.	<input type="checkbox"/>		
3. Controllo olio e periodi di manutenzione secondo il manuale di uso e manutenzione. Oil inspection points and service intervals accordance to instructions manual.	<input type="checkbox"/>		
4. Sostituzione e pulizia dei filtri. Renewing and cleaning filters	<input type="checkbox"/>		
D Commenti/Comments			
Con la presente si certifica che la macchina in oggetto è stata consegnata in condizioni soddisfacenti, che il manuale di uso e manutenzione è stato consegnato e che sono state date tutte le istruzioni di uso e manutenzioni della macchina incluso i dispositivi di sicurezza. It is hereby certified that the above mentioned machine was handed over in satisfactory condition, that the instructions manual was handed over and the instructions in operating and service of the machine, including its safety regulations, were given.			
Nome: Name:	Cliente - Customer	Venditore - Dealer	CAMS service engineer
Firma: Signature:			
Data: Date:			

Tab. 1-1

1.3 WARRANTY

The warranty period and methods are defined during the contractual phase, according to the general conditions of supply.

The warranty only applies to interventions due to mechanical or assembly defects and does not affect the wear parts.

The warranty becomes void in the following cases:

- Machine use according to methods not specified by the manufacturer and described in paragraph 7.3 and following of "COMMISSIONING, START AND STOP".
- Use of non-original spare parts in relation to crusher components and its parts;
- Periodic maintenance not performed according to the methods and times described in the "maintenance" chapter.
- Precarious installation of the machine (see chap. "Installation and operation");
- Interventions not carried out by the Manufacturer's technicians.



IMPORTANT

To activate the warranty, return the testing sheet in tab. 1-1 to the Manufacturer, duly completed and signed; a copy of this sheet is delivered together with the EC certificate.

1.4 EXAMPLE OF EC DECLARATION OF CONFORMITY

The undersigned

CAMS S.r.l.
Via Giulio Golini, 301
40024 Castel San Pietro Terme BO Italy

Person authorised to compile the technical documentation: CAMS srl

Resident C/o CAMS S.r.l. Via Giulio Golini, 301
40024 Castel San Pietro Terme (BO) - Italy

The machine described below

Model:	APR TM 850-2s
Type:	Mobile crushing and screening plant
Serial:	-----
Year of manufacture:	-----

Declares, under its sole responsibility, conformity with the legislative requirements of Directives:

- Machinery Directive 2006/42/EC
- EMC Directive 2004/108/EC
- Low Voltage Directive 2006/95/EC
- Directive 2000/14/EC

Name: Eng. Marco Trentini

Role: Chief Executive Officer

Place and date
Castel San Pietro Terme
15/03/2010

Signature

.....

1.4.1 EC Identification plate

The machine identification plate, inclusive of CE marking (Fig. 1-2) has been applied on the rear-right side (Fig. 1-3) of the machine in question by means of welding or riveting.

This machine meets the safety requirements required by the Machinery Directive 2006/42/EC and the CE marking, that notifies compliance, is present on the machine.

The machine identification plate must never be removed and it must always be legible. In case of damage, a duplicate must be requested upon return of the original.

The machine cannot be marketed without identification plate.

It is possible that an EC plate is present on machine elements, but this only relates to the component on which it is applied and described on the same.



Fig. 1-3

Listed below are the various plates on the plant relating to the individual components.

Fig.1.4 Engine in the engine compartment left side.

Fig.1.5 Generator in the engine compartment right side.

1.5 REGULATORY REFERENCES

1.5.1 Directives and standards concerning the safety of the machines

Directive and regulatory framework applicable to the machine:

- Machinery Directive 2006/42/EC.
- EMC Directive 2004/108/EC.
- Low Voltage Directive 2006/95/EC.
- Directive 2000/14/EC

1.6 ASSISTANCE

When requesting for assistance intervention, clearly specify the problems encountered so that the most appropriate material can be used. CAMS S.r.l. guarantees the availability of the spare parts of this machine for at least ten years from the date of manufacture.

Poor maintenance or improper use can lead to failures and unpredictable wear.

For under warranty assistance and/or request of maintenance or repair interventions, contact your dealer or directly:

CAMS S.r.l.
Via Giulio Golini, 301- 40024 Castel San Pietro Terme (Bologna)
Tel. +39 051 6946611
camsrecycling.com
E-mail cams@camsrecycling.com

We now call for a careful reading of this manual